

Product Overview

The Qorvo® QPF4518 is an integrated front end module (FEM) designed for Wi-Fi 5 (802.11ac) systems. The compact form factor and integrated matching minimizes layout area in the application.

Performance is focused on optimizing the PA for a 5V supply voltage that conserves power consumption while maintaining the highest linear output power and leading edge throughput.

The receive path is pinned out so external filtering can be added in the optimal position. Integrated die level filtering for 2nd and 3rd harmonics as well as 2.4 GHz rejection for DBDC operation are included.

There are two options for power detect, a DC power detector which has voltage output and an RF power detector with an RF output from a directional coupler.

The QPF4518 integrates a 5 GHz power amplifier (PA), single pole two throw switch (SP2T) and bypassable low noise amplifier (LNA) into a single device.



24 Pin 5x3 mm QFN Package

Key Features

- 5150 – 5925 MHz
- P_{OUT} = +23 dBm MCS9 VHT80 -35 dB Dynamic EVM
- P_{OUT} = +24.5 dBm MCS7 HT20/40 -30 dB Dynamic EVM
- P_{OUT} = +25 dBm MCS0 HT20 Spectral Mask Compliance
- 160 MHz Bandwidth and MCS11 Capable
- Optimized for +5 V Operation
- 32 dB Tx Gain
- 2 dB Noise Figure
- 16 dB Rx Gain & 6.5 dB Bypass Loss
- 25 dB 2.4 GHz Rejection on Rx Path
- Integrated RF Power Detector Coupler as well as DC Power Detector

Functional Block Diagram

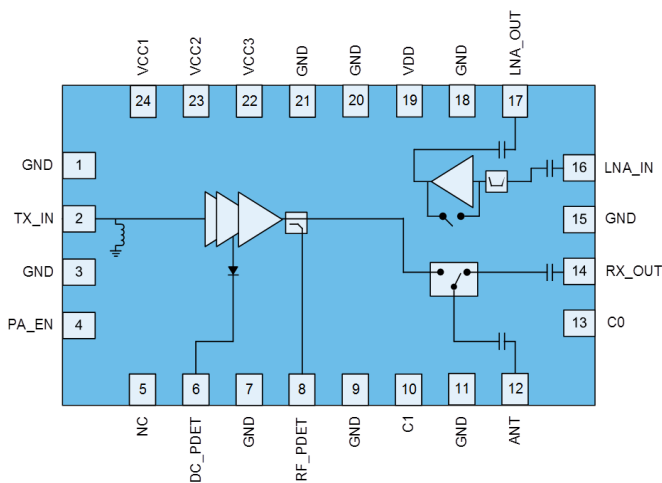

Top View

Applications

- Access Points
- Wireless Routers
- Residential Gateways
- Customer Premise Equipment
- Internet of Things

Ordering Information

Part Number	Description
QPF4518SB	Sample bag with 5 pieces
QPF4518SQ	Sample bag with 25 pieces
QPF4518SR	7" reel with 100 pieces
QPF4518TR13	13" reel with 2,500 pieces
QPF4518PCK401	Assembled Evaluation Board + 5 pcs

Handling Precautions

Parameter	Rating	Standard
ESD – Human Body Model (HBM)	Class 1B (750V)	ANSI/ESD/JEDEC JS-001
ESD – Charged Device Model (CDM)	Class C2a (700V)	ANSI/ESD/JEDEC JS-002
MSL – Moisture Sensitivity Level	Level 2	IPC/JEDEC J-STD-020



Caution!

ESD sensitive device

Solderability

Compatible with both lead-free (260 °C max. reflow temperature) and tin/lead (245 °C max. reflow temperature) soldering processes.

Package lead plating: NiPdAu

RoHS Compliance

This part is compliant with the 2011/65/EU RoHS directive (Restrictions on the Use of Certain Hazardous Substances in Electrical and Electronic Equipment), as amended by Directive 2015/863/EU.

This product also has the following attributes:

- Lead free
- Halogen Free (Chlorine, Bromine)
- Antimony Free
- TBBP-A (C₁₅H₁₂Br₄O₂) Free
- SVHC Free



Contact Information

For the latest specifications, additional product information, worldwide sales and distribution locations:

Web: www.qorvo.com

Tel: 1-844-890-8163

Email: customer.support@qorvo.com

Important Notice

The information contained herein is believed to be reliable; however, Qorvo makes no warranties regarding the information contained herein and assumes no responsibility or liability whatsoever for the use of the information contained herein. All information contained herein is subject to change without notice. Customers should obtain and verify the latest relevant information before placing orders for Qorvo products. The information contained herein or any use of such information does not grant, explicitly or implicitly, to any party any patent rights, licenses, or any other intellectual property rights, whether with regard to such information itself or anything described by such information. **THIS INFORMATION DOES NOT CONSTITUTE A WARRANTY WITH RESPECT TO THE PRODUCTS DESCRIBED HEREIN, AND QORVO HEREBY DISCLAIMS ANY AND ALL WARRANTIES WITH RESPECT TO SUCH PRODUCTS WHETHER EXPRESS OR IMPLIED BY LAW, COURSE OF DEALING, COURSE OF PERFORMANCE, USAGE OF TRADE OR OTHERWISE, INCLUDING THE IMPLIED WARRANTIES OF MERCHANTABILITY AND FITNESS FOR A PARTICULAR PURPOSE.**

Without limiting the generality of the foregoing, Qorvo products are not warranted or authorized for use as critical components in medical, life-saving, or life-sustaining applications, or other applications where a failure would reasonably be expected to cause severe personal injury or death.

Copyright 2019 © Qorvo, Inc. | Qorvo is a registered trademark of Qorvo, Inc.